

## KFM LED ESD

ESD-safe industrial LED magnifier.

LUXO



KFM LED ESD is especially made for the electronics industry where electrostatic discharges can prove fatal for electronic components. It is designed to drain away static charges as they occur in a controlled manner.

KFM LED ESD has a robust all-metal construction with sleek design, a flexible arm and excellent light output. The flexibility of the joint between lamp head and arm makes exact positioning easy. The 127 mm optical grade glass lens is of the highest quality, for the best possible viewing experience. The quality and exact positioning of the LEDs allows for virtually shadow-free magnification and excellent colour rendering.

### Maximum flexibility and precision

The flexibility of the joint between lamp head and arm makes exact positioning easy. The spring balanced arm provides maximum vertical and horizontal movement, and will always stay in the right position without drifting. Colour: Black

The standard version is supplied with a 3 or 5 diopter glass lens. A cloth cover is provided to protect the lens from dust and to prevent the luminaire from inadvertently turning into a burning glass.

### LED: Light source of the future!

KFM LED ESD is equipped with two semi-circular LED modules with a total energy consumption of only 11W. The modules are dimmable, and automatically turn themselves off after 4 or 9 hours in order to save energy. Light emitting diodes have an incredibly long life span. The diodes in KFM LED ESD have a life expectancy of 50.000 hours. That means 25 years or more with normal use. You will never have to change the light source!

### About magnification

Follow this link to read more about the principles of magnification, and how a Luxo magnifier can make a difference for people in many different fields of life.

• [Luxo illuminated magnifiers](#)

# KFM LED ESD

---

## TECHNICAL DESCRIPTION

---



---

### LIGHT SOURCE

Supplied with 2 semi-circular LED modules with a total energy consumption of only 11W. Correlated colour temperature (CCT) is 4000°K. Colour rendition index (CRI) is 80. The LED modules are dimmable, 1-100%.

---

### BODY MATERIAL & COLOUR

Steel arm, shade in aluminium. Colour: Black.

---

### MOUNTING

Standard with table clamp (AH clamp). Other table clamps, integrated table mounts and trolley are available on request.

---

### OPTICS

Standard with 3 or 5 diopter crown glass lens. For additional magnification a secondary lens, 4D, 6D or 10D can be attached to the magnifier.

---

### POWER SUPPLY

Delivered with 2m cable and plug.

---

### ARM TECHNOLOGY & MOVEMENT

Parallel, three-pivot arm. Arm length is 105 cm.

A shut-off function is integrated. The light will automatically shut off after 4 or 9 hours.

---

## MEASUREMENT DRAWINGS

---

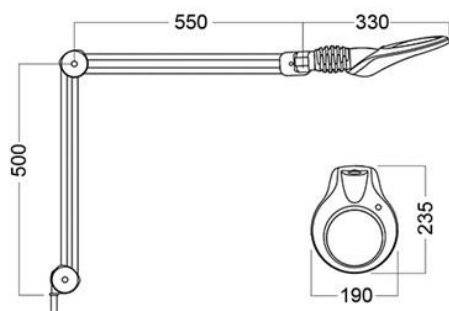

KFM LED ESD

# KFM LED ESD

---

## GALLERY

---



KFM LED ESD



KFM LED ESD