

DCD DUAL-CARTRIDGE DISPENSE SYSTEM

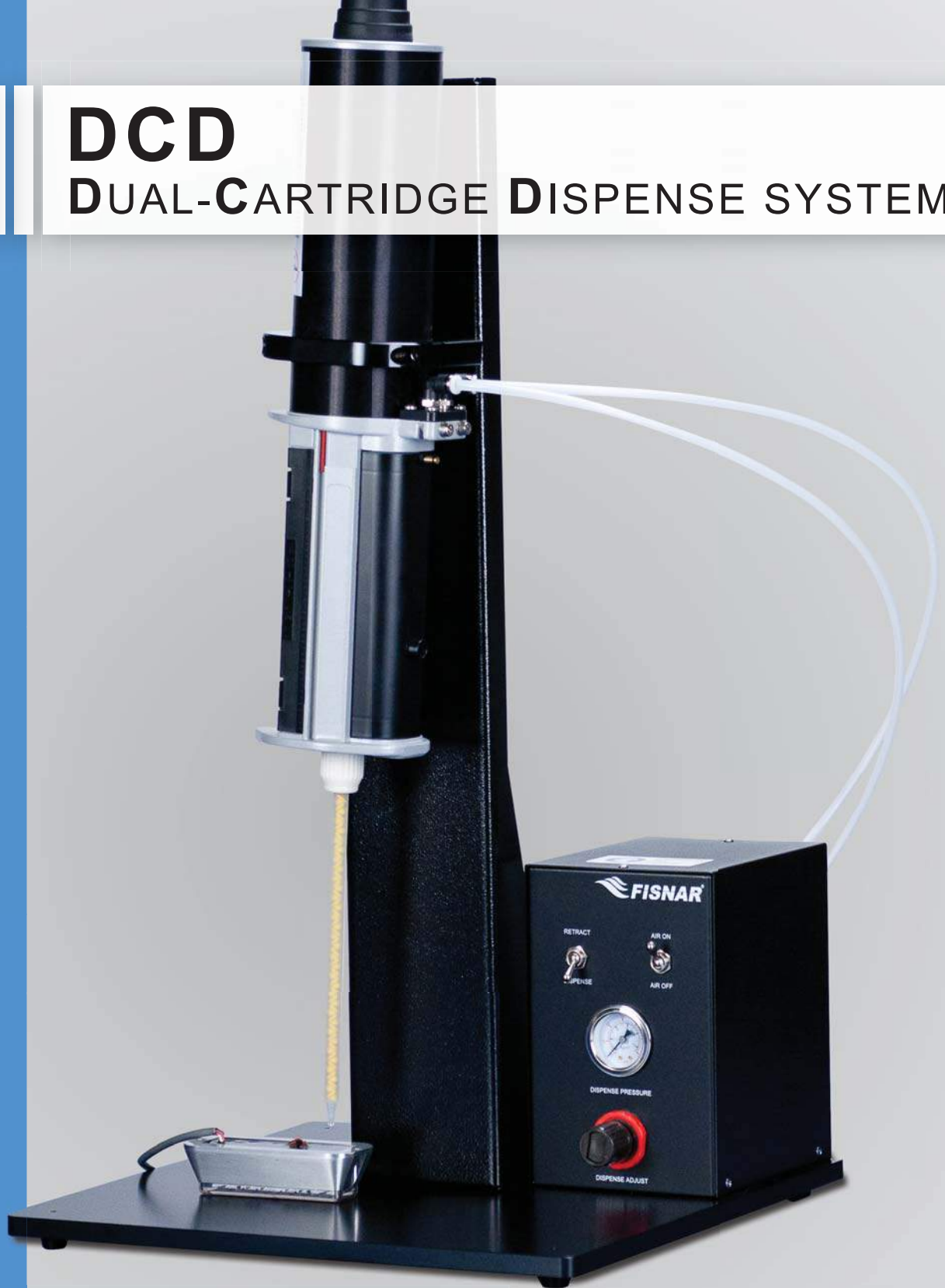

 **FISNAR**[®]

Quality Performance Dispensing Solutions

DCD

Dual-Cartridge Dispense System

The model DCD is an excellent cost-effective solution for low volume mixing and dispensing of two-part materials supplied in dual cartridges. The fully portable bench-mounted system is simple to install and program for accurate two-part dispensing.

DCD systems include a pneumatically actuated dual-cartridge piston dispenser, which applies pressure to accurately dispense materials contained in a dual cartridge. A static mixer finally combines the two materials. A piston retraction control, allows for easy loading and unloading of the cartridge.

Machines are available to suit 200ml and 400ml dual cartridges.

The dispenser is mounted on a robust bench support, resulting in a system that can be adjusted in height and angle for dispensing. A compact controller provides all the necessary air logic functions, and maintains control of air pressure to the dispenser.

A pinch-valve is included with each system for increased accuracy and drip-free dispensing of low-viscosity materials. The valve is fitted to the exit tip of the static mixer, and operated by an air portal on the controller. A pneumatic foot pedal enables a hands-free operation and assists in eliminating operator fatigue.

Model

DP200-1	200ml system
DP200A-1	200ml system w/ SL101N digital timer
DP400-1	400ml system
DP400A-1	400ml system w/ SL101N digital timer



DP400A-1
dispense system
w/ digital timer

Dimensions

(measurements are in millimeters)

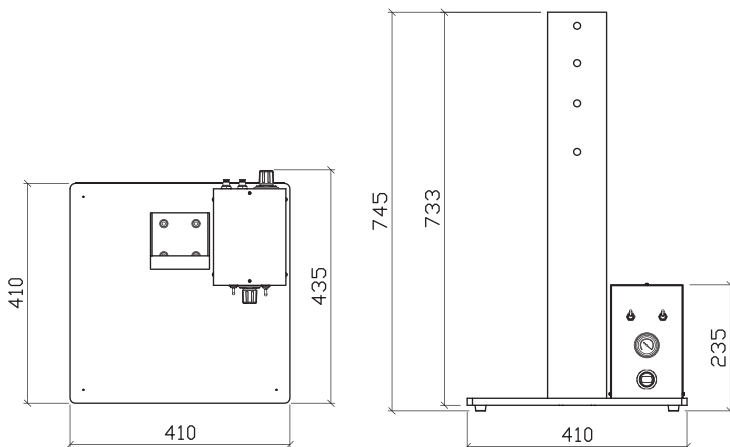

Specifications

DCD Controller

Operating pressure:	87 psi maximum
Compressed air supply:	100 psi maximum
Air requirements:	ISO 8573-1, 2.4.2
Pressure adjustments:	Variable
Pneumatic connections:	1/4 inch
Weight w/o foot pedal:	32 lbs. (14.5 kg.)
Foot pedal weight:	4 lbs. (1.8 kg.)

Cartridge Dispense Tool

Operating pressure:	87 psi maximum
Compressed air supply:	100 psi maximum
Air requirements:	ISO 8573-1, 2.4.2
Pressure adjustments:	Variable
Sound level:	83 dBA

Weight

DP200:	3.52 lbs. (1.6 kg.)
DP400:	4.85 lbs. (2.2 kg.)

Codes and standards applied

Machine directive:	2006/42/EC
Compressed air quality class:	EN ISO 8473-1:2000
Pneumatic connections:	1/4 inch



Tel: (973) 646-5044 • E-mail: info@fisnar.com
www.fisnar.com